

# Sealed Enclosures

www.sealed-enclosures.com

battery box – undergoing a vacuum test



## Specification

Material	Rigid Polyurethane	
	Metric	Imperial
Units		
Internal volume	11 Litres	2.9 US/gal
Depth Rating	40 Metres	131 feet
Internal Length	350 mm	13.78"
Internal Width	200 mm	7.87"
Internal Depth	150 mm	5.90"
Thickness of the side wall	20 mm	0.79"
Weight in air	14 kg	30.9 lb
Weight in water	-9 kg	-19.8 lb

3RD ANGLE

© 2006 THE INFORMATION CONTAINED WITHIN THIS DRAWING IS THE COPYRIGHT OF SEALED ENCLOSURES LTD PTY AND MAY NOT BE USED WITHOUT PRIOR CONSENT

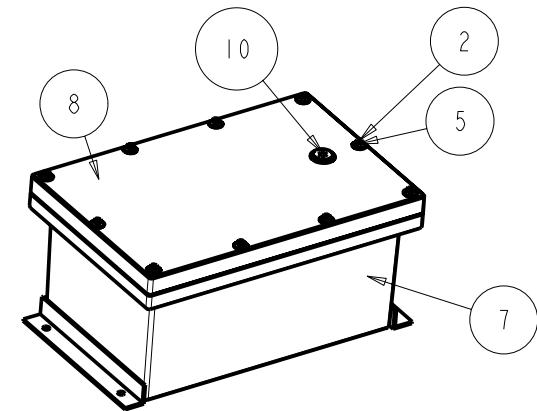
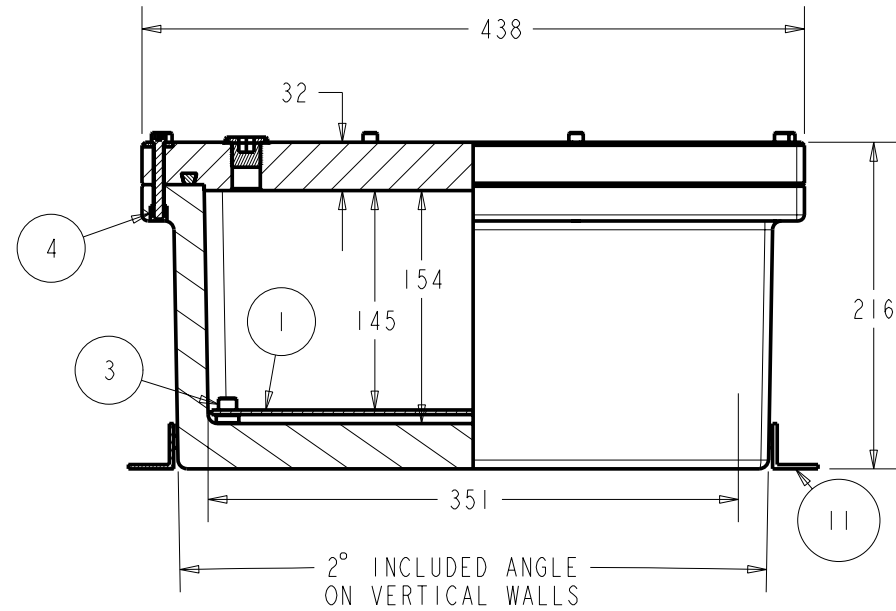
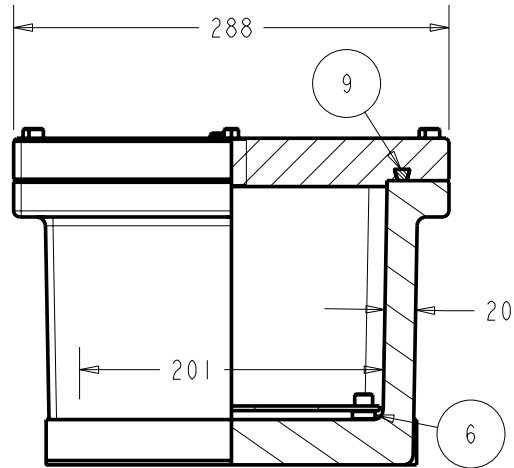

# OTHER MATERIALS AVAILABLE ON REQUEST

ITEM	FILE NAME	DESCRIPTION	MATERIAL	QTY
1	SUB_PLATE	MOUNTING PLATE	# ST/STEEL GRADE 304	1
2	N1-4X2S	SCREW; SOC. CAP; 1/4-20X2; S.S.	A4	10
3	N5-16X1S	SCREW; SOC. CAP; 5/16-18X1; S.S.	A4	4
4	UNC_NUT	1/4" UNC NYLOC NUT	A4	10
5	WASHER	OVERSIZE WASHER	A4	10
6	SPACER	SUB PLATE SPACER	ACETAL	4
7	BATTERY_BOX_BODY	BATTERY BOX BODY	RIGID POLYURETHANE	1
8	BATTERY_BOX_LID	BATTERY BOX LID	RIGID POLYURETHANE	1
9	SILICON_SEAL	CAPTIVE GASKET SEAL	SILICON RUBBER	1
10	BLANKING_PLUG	BLANKING PLUG M25 X 1.5	ST/STEEL 316S33	1
11	FIXING_BRACKET	ANGLE SECTION 30 X 30 X 3	ST/STEEL 316S33	2

 <p>FACTORY 4, 43-47 RIVERSIDE AVENUE WERRIBEE VICTORIA 3030 AUSTRALIA Tel +61 (0)3 8742-3525 Fax +61 (0)3 9923-6497</p>	TITLE BATTERY BOX	PROJECT STANDARD PRODUCT	SCALE 0.200	DRAWING NO 4005	ISSUE 1	ISSUE DATE 10th May 2005
	RATING 40 METERS	NOTES CAST FROM RIGID PU	UNITS mm	DRAWN BY E Bowes	CHECKED BY A B	SHEET 1 OF 6